

PERI Bérleti kritériumok

GT 24 rácsos fatartó



Kapcsolat

PERI kft,
zszaluzatok, állványzatok,
mérnöki szolgáltatás

H-1181 Budapest
Zádor u. 9.
Tel.: +36-1-296-09-60
www.peri.hu

Tartalom	Oldal	Változás	Dátum ü	Oldal
Tartó öv	3	Új verzió	02/2021 Sz.L.	
Gerinc rács	14			
Védősapka	17			
Magyarázat	19			

PERI Bérleti kritériumok

GT 24 rácsos fatartó



GT 24 rácsos tartó	Sorsz.	Leírás	Cikkszám
	1	Tartó öv	
	2	Gerinc rács	
	3	Horganyzott acél sapka (726040) kifutó	
	4	Acél szegecs (726041) kifutó	

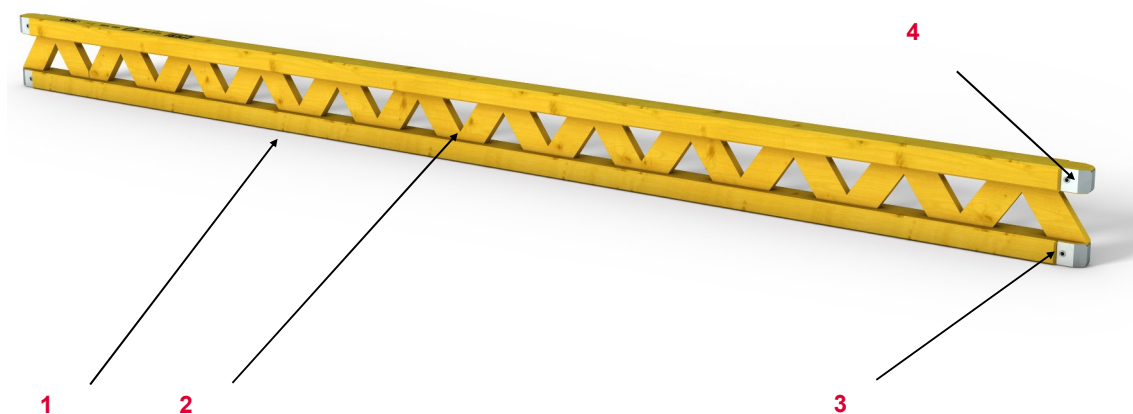

PERI Bérleti kritériumok

GT 24 rácsos fatartó











Termék	Cikkszám
GT 24 L = 0,90 m	075100
GT 24 L = 1,20 m	075120
GT 24 L = 1,50 m	075150
GT 24 L = 1,80 m	075180
GT 24 L = 2,10 m	075210
GT 24 L = 2,40 m	075240
GT 24 L = 2,70 m	075270
GT 24 L = 3,00 m	075300
GT 24 L = 3,30 m	075330
GT 24 L = 3,60 m	075360
GT 24 L = 3,90 m	075390
GT 24 L = 4,20 m	075420
GT 24 L = 4,50 m	075450
GT 24 L = 4,80 m	075480

Termék	Cikkszám
GT 24 L = 5,10 m	075510
GT 24 L = 5,40 m	075540
GT 24 L = 5,70 m	075570
GT 24 L = 6,00 m	075600

PERI Bérleti kritériumok

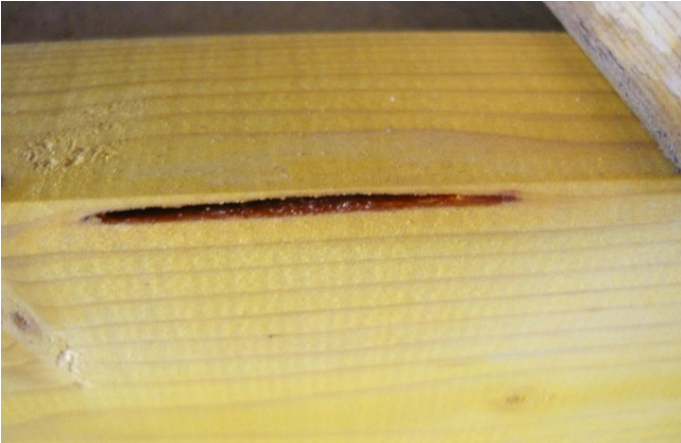
GT 24 rácsos fatartó











Tartó öv - általános állapot	Leírás	Instrukció	Fizetési kondíció	Típus
	01.01 Kéreg benövés			
	01.02 Gyanta zárvány ■ ≤ 5 mm			

PERI Bérleti kritériumok

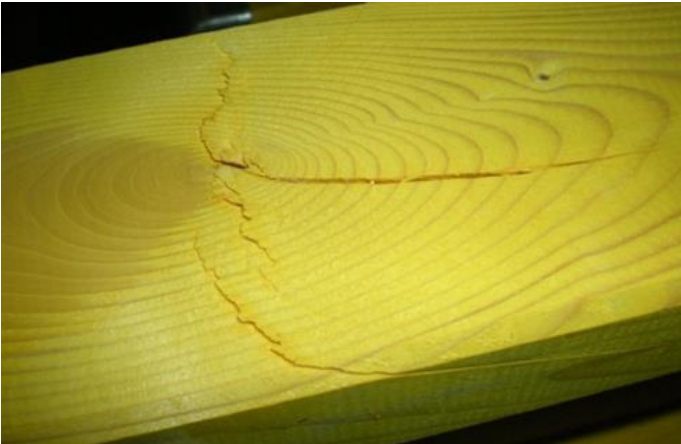
GT 24 rácsos fatartó



Tartó öv - általános állapot	Leírás	Instrukció	Fizetési kondíció	Típus
	01.03 Csomó az öv élében			
	01.04 Gyűrűs repedés	 		

PERI Bérleti kritériumok

GT 24 rácsos fatartó



Tartó öv kitöredezése	leírás	Instukció	Fizetési kondíció	Típus
-----------------------	--------	-----------	-------------------	-------

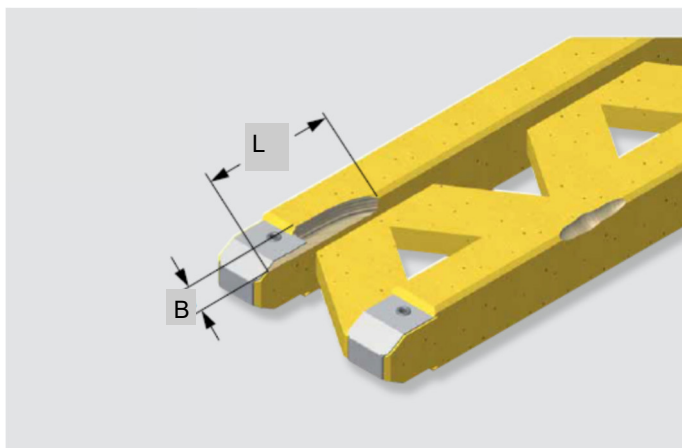

01.05 Kitöredezés a tartó övön

- ha $B \leq 33$ mm széles és $L \leq 35$ cm hosszú



- amennyiben $L > 35$ cm hosszú
- és $B \leq 10$ mm széles

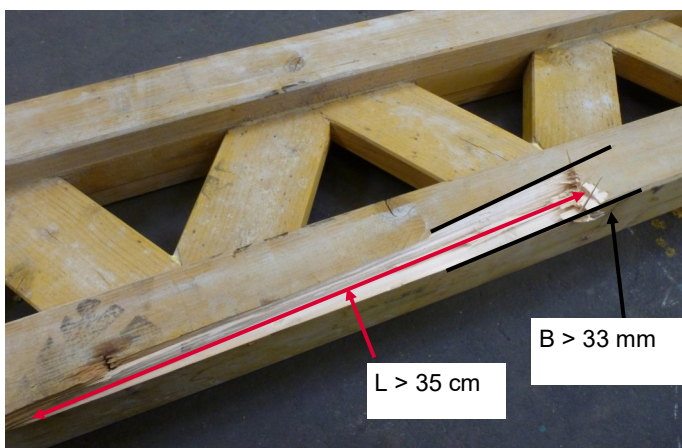

01.06 Kitöredezés a tartó övön

- $B > 33$ mm széles











- vagy $L > 35$ cm hosszú
- és $B > 10$ mm széles



PERI Bérleti kritériumok

GT 24 rácsos fatartó











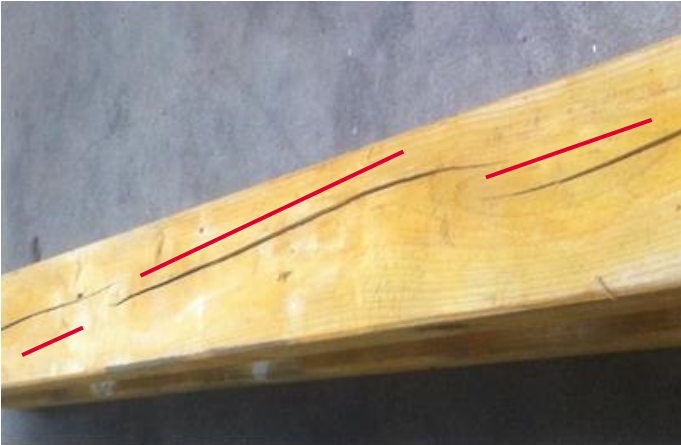

Tartó öv törése	Leírás	Instrukció	Fizetési kondíció	Típus
	01.07 Tartó öv törése <ul style="list-style-type: none">■ Túlterhelés okozta törés			
	01.08 Törés szálirányra merőlegesen			

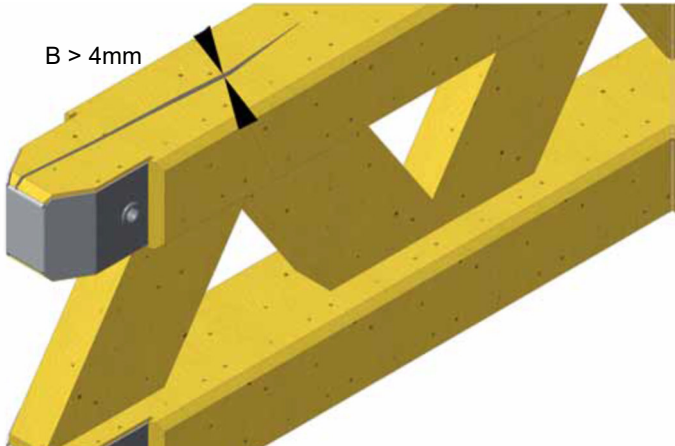
PERI Bérleti kritériumok

GT 24 rácsos fatartó



Tartó öv repedése	Leírás	Instrukció	Fizetési kondíció	Típus
	<p>01.09 Kiszáradás miatti repedés</p> <ul style="list-style-type: none"> ■ Repedés szálirányban ■ és nem folyamatos repedés ■ és max. szélesség ≤ 4 mm ■ és max. hosszúság 1 m 			
	<p>01.10 Kiszáradás miatti repedés</p> <ul style="list-style-type: none"> ■ Szélesség $B > 4$ mm ■ Hosszúság $L > 1$ m 	 	 	 

PERI Bérleti kritériumok

GT 24 rácsos fatartó



Tartó öv repedése	Leírás	Instrukció	Fizetési kondíció	Típus
-------------------	--------	------------	-------------------	-------



01.11 Nem megfelelő használatból eredő sérülések (túlelérés, zuhanás vagy szegezés)

- Sérülésből eredő repedés / benyomódás (pl. Jelentős mértékben eldeformálódott védősapka)



PERI Bérleti kritériumok

GT 24 rácsos fatartó











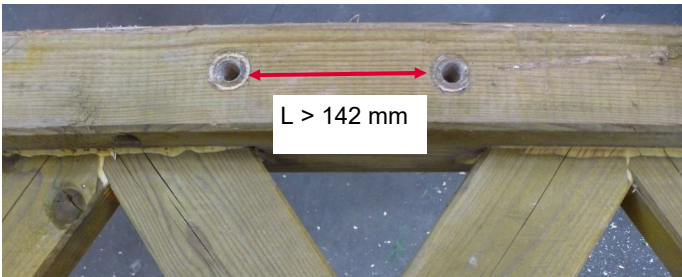





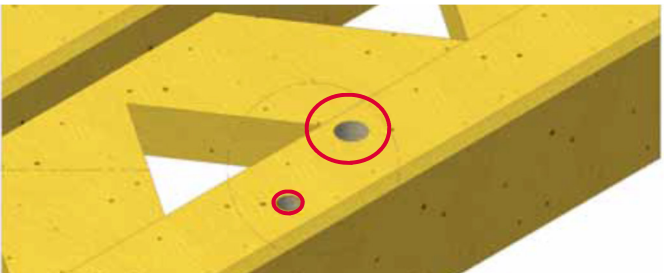

Tartó öv furatai	Leírás	Instrukció	Fizetési kondíció	Típus
	<p>01.12 Furatok $\varnothing \leq 4$ mm</p> <ul style="list-style-type: none"> ■ Max. 4 lyuk középen (egy vonalban) ■ és ha a távolság köztük L min. 80 mm 			
	<p>01.13 Furatok $4 \text{ mm} \leq \varnothing \leq 8 \text{ mm}$ a tartó öv végén</p> <ul style="list-style-type: none"> ■ Max. 3 lyuk középen (egy vonalban) ■ és a távolság köztük L min. 80 mm 			
	<p>01.14 Furatok $4 \text{ mm} \leq \varnothing \leq 8 \text{ mm}$</p> <ul style="list-style-type: none"> ■ Max. 2 lyuk középen (egy vonalban) ■ és a távolság köztük L min. 142 mm 			

PERI Bérleti kritériumok

GT 24 rácsos fatartó



Tartó öv furatai	Leírás	Instrukció	Fizetési kondíció	Típus
	<p>01.15 M6/M8 lyuk a tartó öv közepén</p> <ul style="list-style-type: none"> ■ Max. 2 lyuk közepén (egy sorban) ■ és a távolság köztük L min. 142 mm 	 		
	<p>01.16 Lyuk 8 mm $4\text{ mm} \leq \varnothing \leq 12\text{ mm}$ a tartó övön</p> <ul style="list-style-type: none"> ■ Max. 1 lyuk a rácsköz közepén és tartóöv közepén 	 		
	<p>01.17 Lyuk 8mm $8\text{ mm} \leq \varnothing \leq 12\text{ mm}$ a tartó övön</p> <ul style="list-style-type: none"> ■ Több, mint 1 lyuk a egy rácsközben ■ vagy $\varnothing > 12\text{ mm}$ 	 	 	 

PERI Bérleti kritériumok

GT 24 rácsos fatartó











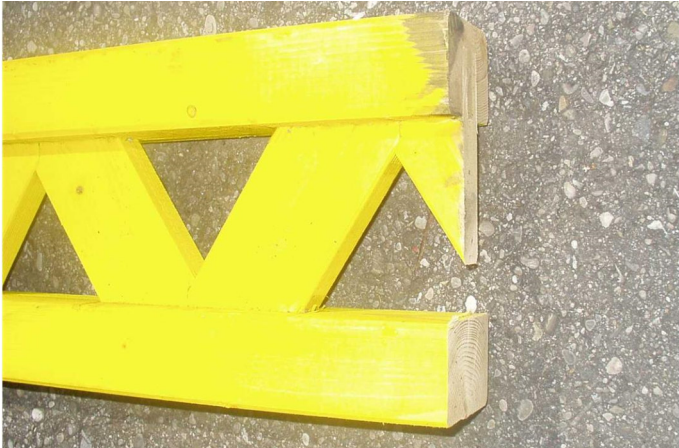



Bevágás tartó övben	Leírás	Instrukció	Fizetési kondíció	Típus
	<p>01.18 Bevágás a tartó övben (szálirányra merőlegesen)</p> <ul style="list-style-type: none"> ■ Mélység ≤ 2 mm a rácsok között ■ vagy > 2 mm mély 	<p>✓ </p> <p></p>	<p></p> <p></p>	<p></p> <p></p>
	<p>01.19 Bevágás a tartó övben</p> <ul style="list-style-type: none"> ■ Bevágás a tartó övben szálirányban $B \leq 5$ mm (szélesség) ■ és max. 1 vágás két tartó rács között 	<p>✓ </p>	<p></p>	<p></p>
	<p>01.20 Bevágás a tartó övben</p> <ul style="list-style-type: none"> ■ Bevágás a tartó övben szálirányban ≤ 5mm ■ és több, mint 1 vágás két tartó rács között ■ Vagy mélység $d > 5$mm 	<p></p> <p></p>	<p></p> <p></p>	<p></p> <p></p>

PERI Bérleti kritériumok

GT 24 rácsos fatartó



Tartó öv	Leírás	Instrukció	Fizetési kondíció	Típus
	<p>01.21 A fatartó ügyfél által történő elvágása</p>			
	<p>01.22 A tartó öve zsaluvibrátor miatt károsodott</p> <ul style="list-style-type: none"> ■ Benyomódás $\leq 3,0$ mm ■ vagy benyomódás $> 3,0$ mm 	<ul style="list-style-type: none">    	<ul style="list-style-type: none">   	<ul style="list-style-type: none">  

PERI Bérleti kritériumok

GT 24 rácsos fatartó



Gerinc rács	Leírás	Instrukció	Fizetési kondíció	Típus
-------------	--------	------------	-------------------	-------



01.23 Gerinc rács furatok

- Furat $\leq \varnothing 18$ mm
- és max. egy lyuk / rács elem



- Furat $\leq \varnothing 18$ mm
- és több, mint egy lyuk / rács elem



- vagy furat $> \varnothing 18$ mm



PERI Bérleti kritériumok

GT 24 rácsos fatartó



Gerinc rács vágása, hasadása	Leírás	Instrukció	Fizetési kondíció	Típus
------------------------------	--------	------------	-------------------	-------

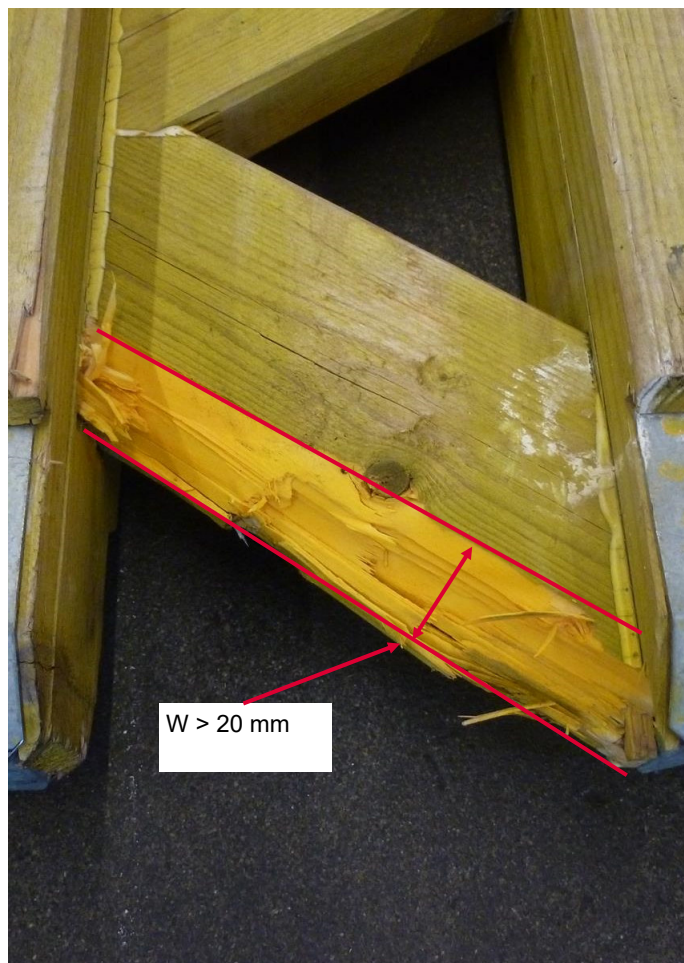

01.24 Hasadás a tartó rácson

- Hasadás szélessége $W \leq 20$ mm
- Vagy hasadás szélessége $W > 20$ mm
- Vagy eltörött



PERI Bérleti kritériumok

GT 24 rácsos fatartó



Gerinc rács repedése / törése	Leírás	Instrukció	Fizetési kondíció	Típus
-------------------------------	--------	------------	-------------------	-------



01.25 Repedés / törés

■ törés száliránnyal párhuzamosan
 $B > 2 \text{ mm}$















■ vagy törés száliránnyal párhuzamosan max.széllesség $B \leq 2 \text{ mm}$



PERI Bérleti kritériumok

GT 24 rácsos fatartó



Védő sapka	Leírás	Instrukció	Fizetési kondíció	Típus
	<p>01.26 Védősapka letört</p> <ul style="list-style-type: none"> Védősapka megrongálódott, hiányzik 			
	<p>01.27 Fatartó szennyeződése</p> <ul style="list-style-type: none"> betonszennyeződés az övön és a gerincen (271100) 			
	<ul style="list-style-type: none"> Jelentős betonszennyeződés az övön és a gerincen (271101) 		 	

PERI bérleti kritériumok ikonok



Icon	Jelentés	Icon	Jelentés	Icon	Jelentés
	Nem OK — kicselezendő		Ügyfélnek leszámházandó		Optikai kár
	OK– marad a bérleti parkban		Nincs számlázás		Funkcionális sérülés
	Selejt anyag – biztonsági okokból az anyagot tilos kiadni		Anyagot levágni		Funkcionális sérülés — anyag kiadása nem engedélyezett
	Javítás az előírások szerint		Anyagot megjelölni		Statikai sérülés — anyag kiadása nem engedélyezett
	Hideg egyengetés — utána a varratokat és a környékét ellenőrzni kell		Sérült anyag cseréje		
	Javítás gazdaságosság függvényében		Hiányzó anyag cseréje		
	Megtisztítani az anyagot				